

## Isotron® accelerometer Model 35B

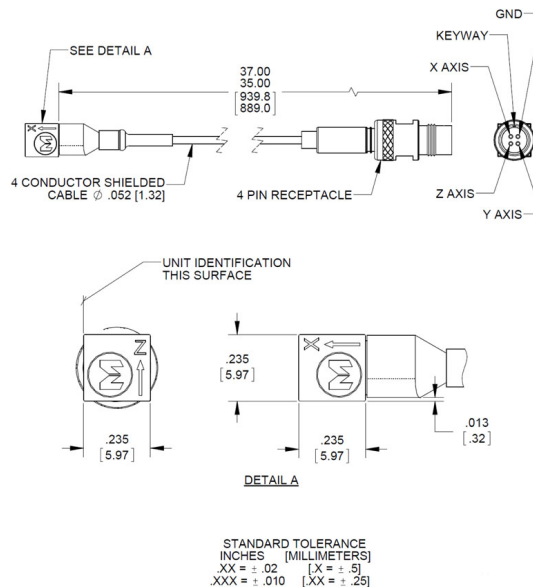
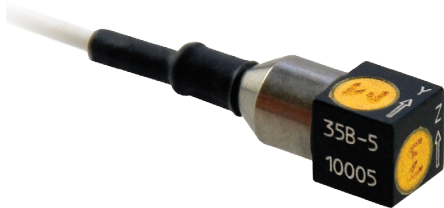

Endevco model 35B is an ultra-miniature, adhesive mounted triaxial piezoelectric accelerometer with integral electronics. Its tiny size, 0.235 inch cube, and light weight, 0.55 grams (sensor only), make it ideal for measuring vibration on very small objects. The 35B has an integral three-foot cable that terminates to a single threaded 1/4-28 4-pin connector. The 35B is available in three sensitivities – 2.5 mV/g, 5 mV/g and 10 mV/g.

The model 35B features Endevco's Piezite Type P-8 ceramic crystal operating in radial shear model which exhibits excellent output sensitivity stability over time. The accelerometer incorporates an internal hybrid signal conditioner in a two-wire system, which transmits its low impedance voltage output through the same cable that supplies the required constant current power. The case is isolated from the mounting surface by an anodized coating over the accelerometer's aluminum housing. A removal tool is included with the accelerometer to ensure proper removal in the field.

This product is fully compliant to the European Union's Low Voltage Directive, 2006/95/EC and EMC Directive 2004/108/EC and is eligible to bear the CE Mark.

TYPICAL FREQUENCY RESPONSE, MODEL 35B

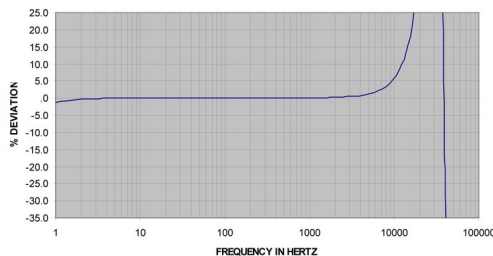

### Key features

- World's smallest triaxial IEPE accelerometer
- Anodized aluminum housing providing case isolation
- Miniature, 0.235 inch cube
- Lightweight, 0.55 grams
- Three sensitivity options available – 2.5, 5 and 10 mV/g
- Three-foot integral cable terminating to 4-pin connector

## Isotron® accelerometer

### Model 35B

#### Specifications

The following performance specifications conform to ISA-RP-37.2 (1964) and are typical values, referenced at +75°F (+24°C) and 100 Hz, unless otherwise noted. Calibration data, traceable to National Institute of Standards and Technology (NIST), is supplied.

Dynamic characteristics	Units	35B-2	35B-5	35B-10
<b>Range [1]</b>				
Nominal	g	±2800	±1400	±700
Minimum	g	±1800	±900	±450
<b>Voltage sensitivity</b>				
Nominal	mV/g	2.5	5	10
Tolerance	%		+40/-20	
<b>Frequency response</b>				
Resonance frequency				
Typical	kHz		40	
Minimum	kHz		30	
Amplitude response				
±5%, z- and y-axis	Hz	2 to 8000	2 to 8000	2 to 6000
±5%, x-axis	Hz	2 to 6000	2 to 5000	2 to 4000
Typical frequency response		See typical frequency response curve		
Transverse sensitivity	%		≤5	
Amplitude linearity	%		<2	

#### Electrical characteristics

<b>Output polarity</b>		Acceleration in the direction of the arrow produces positive output		
<b>DC output bias voltage</b>				
Room temperature, +75°F (+24°C)	Vdc		+7.5 to +10.5	
-67°F to +257°F (-55°C to +125°C)	Vdc		+7.0 to +16.0	
Output impedance	Ω		≤700	
<b>Noise floor</b>				
Broadband				
1 Hz to 10000 Hz	μg rms	8000	4000	4000
Spectral				
1 Hz	μg / √Hz	7500	3500	3500
10 Hz	μg / √Hz	300	160	300
100 Hz	μg / √Hz	70	40	80
1000 Hz	μg / √Hz	20	12	30
<b>Grounding method</b>		Case is isolated from mounting surface through anodized coating		
<b>Power requirements</b>				
Supply voltage	Vdc		+24 to +28	
Supply current [2]	mA		+3.5 to +4.5	
Warm-up time [3]	sec		<3	
Recovery time [4]	μsec		<10	
Full scale output voltage	V		±7.0	

#### Environmental characteristics

Temperature range	°F [°C]	-67 to +257 [-55 to +125]		
Humidity		Epoxy sealed, non-hermetic		
Vibration limit (sinusoidal motion) [5]	G	500		
Shock limit [6]	g pk	5000		
Electromagnetic sensitivity	equiv g rms/gauss	0.03		

#### Physical characteristics

<b>Dimensions</b>		See outline drawing		
Weight, without strain relief and cable	grams (oz)	0.55 (0.02)		
Case material		Anodized aluminum		
Connector		4-pin Microtech style		
Mounting [7]		Adhesive		

#### Calibration data supplied

Sensitivity, each axis	mV/g			
Bias, each axis	Vdc			
Frequency response, each axis	%	20 Hz to 8 kHz	20 Hz to 6 kHz	
	dB	8 kHz to 10 kHz	6 kHz to 8 kHz	

## Isotron® accelerometer Model 35B

### Accessories

Product	Description	35B
42952	Removal tool	Included
C-003-CA-005-ZZZZ [8]	Cable assembly 4-pin to 3 BNC	Optional
3027AM3-ZZZ [8]	Cable assembly 4-pin to 3 BNC	Optional
123	Signal conditioner	Optional
133	Signal conditioner	Optional

### Notes

1. Specified limit of sensor at the entire operating temperature range
2. Excessive current supply may cause permanent damage to accelerometer
3. DC bias within 10% of final value
4. Time interval between the moment the sensor is saturated and the moment bias returns within 10% of final value.
5. Destructive limit.
6. Destructive limit. Shock is a one-time event. Shock pulses of short duration may excite transducer resonance. Shock level above the sinusoidal vibration limit may produce temporary zero shift that will result in erroneous velocity or displacement data after integration.
7. Cyanoacrylate adhesives are recommended for temporary mounting applications. To remove the accelerometer, soften the adhesive with the appropriate solvent and use the remove tool supplied with each accelerometer. Striking or applying excessive torque to break the glue bond will cause permanent damage to the transducer.
8. ZZZ or ZZZZ designates cable assembly length in inches
9. Maintain high levels of precision and accuracy using Endevco's factory calibration services. Call Endevco's inside sales force at 866-ENDEVCO for recommended intervals, pricing and turn-around time for these services as well as for quotations on our standard products.
10. Model number definition:

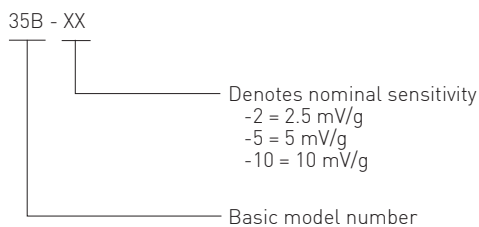

### Contact

#### ENDEVCO

www.endevco.com

Tel: +1 (866) ENDEVCO

[+1 (866) 363-3826]